



PECM Precision Electrochemical Machining



PECM 400/600/800

Your efficient solution for Precise Electrochemical Machining in low- and high-volume serial production.

Meeting the challenge of market demand for increased performance and efficiency requires innovative machining and methods that open up new dimensions of metal machining.

Precise Electrochemical Machining (PECM) is characterized by a number of properties that help customers achieve increased productivity with reduced tool wear and high repeatability having the benefits of competitive cost per part production.

FEATURES and BENEFITS

+ Precision

- Perfect alignment of mechanical rigidity, cathode oscillation, DC pulse, and electrolyte quality ensure consistent results ($\pm 5 \mu\text{m}$) at highest repeatability.
- Temperature compensation system.

+ Productivity

- Ability to machine multiple parts per cycle to achieve more attractive cost per part.
- Roughing, finishing, and polishing in one cycle – part free from burr.
- Feed rate of cathode up to 2mm per minute (dependent on application).
- Automation ready – easy to integrate into production lines.

+ Quality

Real time process monitoring of relevant parameters for controlled production.

+ Environmental friendly

Built-in features provide protection against spillage, corrosion, and vapors.

+ Experience

Years of experience in supplying PECM solutions for serial production in different markets.





**EXTRUDE
HONE®**

TECHNICAL INFORMATION

PECM 400/600/800

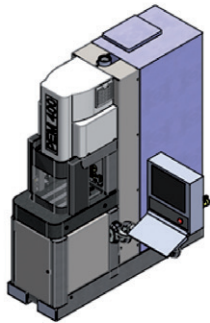

PECM 400

Machine dimensions (WxDxH)
600 x 1860 x 2264 mm

Standalone Electrolyte Unit (WxDxH)
2503 x 2160 x 2476 mm

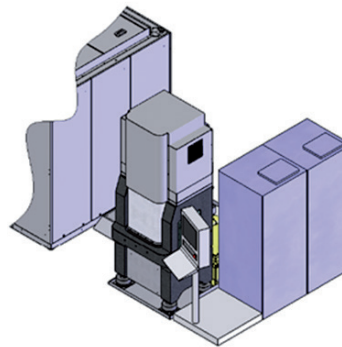

PECM 600/800

Machine dimensions (WxDxH)
1100 x 1600 x 2684 mm

Standalone Electrical cabinet (WxDxH)
2400 x 800 x 1920 mm

Standalone Electrolyte Unit (WxDxH)
2503 x 2160 x 2476 mm

MACHINE CONFIGURATION

	PECM 400	PECM 600	PECM 800
Granite machine frame	x	x	x
Table size (W x D)	380x450 mm	450x450 mm	660x540 mm
Feed Z Axis	direct drive	ball screw drive	ball screw drive
Vibration amplitude & Frequency	free programmable, direct drive	0,2 mm (90Hz) 0,4 mm (50Hz)	0,2 mm (90Hz) 0,4 mm (50Hz)
Modular power generators	1000 A	1200 A modular 2000 A modular	1200 A modular 2000 A modular
max Power available	1000 A	9600 A (8 x 1200A) 8000 A (4 x 2000A)	9600 A (8 x 1200A) 8000 A (4 x 2000A)
integrated ventilation system	x	x	x
User-friendly software with real-time process monitoring as well as long term process graph for superior quality control	x	x	x
Highly advanced short circuit control for increased tool life.	x	x	x
Microfiltration unit integrated into AQUA for highest electrolyte purity.	x	x	x
Control and regulation of all parameters automatically done by the machine.	x	x	x
Electrical Connection	3 P~ N PE 400 V AC 50 Hz (+6%/-10%)		

AVAILABLE OPTIONS

	PECM 400	PECM 600	PECM 800
Chromate reduction unit with sensor	x	x	x
Bipolar Pulsing	x	x	x
Non-Vibration mode	x	x	x
Backpressure unit	x	x	x
60Hz power network setup	x	x	x
Automation interface	x	x	x
Fault remote system	x	x	x
Chamber filter press	x	x	x
Chiller	x	x	x

NOTE: Specifications and availability are subject to change without notice.